

Strata[®] *DK*

Digital Business Telephone Systems

**Cordless Digital Telephone
User Guide**

Publication Information

Toshiba America Information Systems, Inc., Telecommunication Systems Division, reserves the right, without prior notice, to revise this information publication for any reason, including, but not limited to, utilization of new advances in the state of technical arts or to simply change the design of this document.

Further, Toshiba America Information Systems, Inc., Telecommunication Systems Division, also reserves the right, without prior notice, to make such changes in equipment design or components as engineering or manufacturing methods may warrant.

DKA-UG-CRDLS-VC
4016149

Version C.1, May 1999
Version C, April 1998
Version B, October 1997
Version A, August 1997

© Copyright 1999

Toshiba America Information Systems, Inc. Telecommunication Systems Division

All rights reserved. No part of this manual, covered by the copyrights hereon, may be reproduced in any form or by any means—graphic, electronic, or mechanical, including recording, taping, photocopying, or information retrieval systems—without express written permission of the publisher of this material.

Strata is a registered trademark of Toshiba Corporation. Strategy is a registered trademark of Toshiba America Information Systems, Inc.

Trademarks, registered trademarks, and service marks are the property of their respective owners.

Precautions

Before you read anything else, please observe the following:

WARNING! Toshiba *does not* represent this unit to be waterproof. To reduce the risk of fire, electrical shock, or damage to the unit, *do not* expose this unit to rain or moisture.

Rechargeable Nickel-Cadmium Battery Warning

- ◆ This equipment contains a Rechargeable Nickel-Cadmium Battery.
- ◆ Cadmium is a chemical known to the State of California to cause cancer.
- ◆ The Rechargeable Nickel-Cadmium Battery contained in this equipment may explode if disposed of in a fire.
- ◆ *Do not* short circuit the battery.
- ◆ *Do not* charge the Rechargeable Nickel-Cadmium Battery used in this equipment in any charger other than the one designed to charge this battery as specified in this Guide. Using another charger may damage the battery, or cause the battery to explode.

Rechargeable Nickel-Cadmium Batteries Must Be Recycled or Disposed of Properly

- ◆ Residents of Minnesota should contact 1-800-225-PRBA for information concerning reclamation and disposal of Rechargeable Nickel-Cadmium batteries.
- ◆ Residents outside of Minnesota should contact their local authorities for information concerning reclamation and disposal of Rechargeable Nickel-Cadmium batteries.

WARNING! To reduce risk of fire, use only Model EXP9580 or EXP9586 batteries.

CAUTION! To power your Toshiba DKT2004-CB Cordless base unit, use only UL Listed AC Adapter Model AD-9500 Class 2 Power Supply.



Ratings are:

Input: 120VAC 14W

Output: 10VDC 500mA

Important! Charge your battery for 10 hours before using your new Cordless Digital Telephone.

Contents

Introduction

- Organization vi
- How To Use This Manual vi
- Conventions vii
- Important Safety Instructions viii
- Related Documents x

Chapter 1 – The Grand Tour

- Applications12
- Benefits12
- Cordless Digital Telephone Standard Parts14
- Base Unit Controls and Functions15
- Features16

Chapter 2 – Installation

- Removing and Charging Your Battery Pack21
 - Charging Extra Battery Packs22
- Tips on Extending Battery Pack Life23
 - Battery Memory Effect23
 - LCD Low Battery Indicator23

Chapter 3 – Configuration

- Entering Program Mode26

Chapter 4 – The Handset

Handset Controls	29
Handset Volume Level	29
Ringer Volume Level	29
Mute	30
Using the Handset	30
Charging the Handset	31
Switching a Call to Your Cordless Digital Telephone	32
Switching a Call to the Desk Telephone	33
Using Memory	34
Chain Dialing	36

Chapter 5 – Features

Before You Begin	38
Quick Reference	39
Making an Outside Call	39
Making an Outside Call to an ISDN Trunk	40
Making an Internal Call	40
Answering Calls	41
Transferring Calls	41
Conferencing Calls	42
Placing/Retrieving Calls on Hold	44
Using Automatic Hold	45
Calling the Attendant Console	46
Tone/Pulse Dialing	46
Account Code Calls	47
Forced Account Codes	47
Emergency Override of Forced Account Codes	47
Voluntary Account Codes	48
Verified Account Codes	48
Alarm Reset	48
Alert Signaling	49
Automatic Busy Redial (ABR)	49
Automatic Callback	50
Line Queuing with Automatic Callback	51
Auto Redial	52
Call Forward	52

Call Forward-All Calls	53
Call Forward-Busy	54
Call Forward-No Answer	54
Call Forward-Busy/No Answer	55
Call Forward-Cancel	56
Call Forward-External	56
Call Forward-Fixed	57
Call Park Orbits (Release 3 or later)	58
Call Park and Page	59
Call Pickup	59
Directed Call Pickup	59
Group Pickup	60
Calls to Other Groups	61
Call Waiting	61
Direct Station Selection Buttons (Hotline)	62
Do Not Disturb (DND)	62
Door Lock	63
Door Telephone	63
ISDN Outgoing Calling	64
Subaddress	65
LCD Name/Number Display	65
Messaging	66
Calling Station Messaging	66
Cancelling a Calling Station Message	67
Message Waiting	67
[PhDN/MW] Message Waiting	69
Off-hook Call Announce (OCA)	70
Activating Off-hook Announce (OCA)	70
Handset Off-hook Call Announce (HS-OCA) Calling	70
Speaker Off-hook Call Announce (SP-OCA)	71
Override Calls	72
Busy Override	72
DND Override	73
Executive Override	73
Page Announcements	73
Privacy On-Line	74
Privacy Release	75
Release and Answer	76

Speed Dial	77
Storing Station Speed Dial Numbers	77
Stored Station or System Speed Dial Calling	78
Timed Reminders	79
Toll Restriction Override	81
Two (Tandem) Line Connection	82
Using a [DN] Button	82
Using Line Buttons	83

Appendix A – Appendix

Installing Optional Headset	86
Troubleshooting	87
Range and Performance	88
Nine Simultaneous Conversation Channels	89
Radio Interference	89
Specifications	90
Available Optional or Replacement Items	91
Access Codes	92
CO Line Access Codes	95
Feature Access Codes	96
Paging Group Codes	96
Speed Dial Access Codes	97
Installing Optional Headset	100
Troubleshooting	101
Range and Performance	102
Nine Simultaneous Conversation Channels	103
Radio Interference	103
Specifications	104
Available Optional or Replacement Items	105
Access Codes	106
CO Line Access Codes	109
Feature Access Codes	109
Paging Group Codes	110
Speed Dial Access Codes	111

Index113

Tables

1	CO Line Access Codes	85
2	Paging Groups	86
3	External Paging Zones	86
4	Speed Dial Access Codes	87
5	Speed Dial Number Linking	87

Introduction

This guide describes the features and operation of the Toshiba DKT2004-CT 900 MHz Cordless Digital Telephone with Strata DK Business Telephone Systems. To get the most from your cordless digital telephone, please read this guide thoroughly. The Strata DK systems which support this equipment are:

- ◆ DK14
- ◆ DK16e/DK16
- ◆ DK40i/DK40
- ◆ DK424/DK280 (Release 3.0 or higher)

Your Toshiba Cordless Digital Telephone also works with Strata DK24/56/96 systems. For Strata DK24/56/96, Release 4 and Strata DK14 and DK40, see the “Access Codes” section of the Appendix for differences in operation.

Organization

This user guide is divided as follows:

- ◆ **Chapter 1—The Grand Tour** covers an equipment overview by describing the features associated with the cordless digital telephone.
- ◆ **Chapter 2—Installation** covers instructions for installing your cordless digital telephone with your Strata DK System.
- ◆ **Chapter 3—Configuration** covers the configuration options for optimizing the performance of your cordless phone.
- ◆ **Chapter 4—Using the Handset** covers the various controls and features related to operating your cordless phone.
- ◆ **Chapter 5—Operation** covers the practical operation of the cordless digital telephone features.
- ◆ **Appendix** covers descriptions of the Optional Headset, Installation, Troubleshooting, Range, Telephone Line Problems, Specifications, Available Optional or Replacement Items, and Access Codes.

Important! *Before using your new cordless phone, the battery must be charged continuously for 10 hours.*

How To Use This Manual

You can use this guide in a variety of ways, depending on your level of experience with the system and your assigned password level.

If you are a new user of DKAdmin/DKBackup, you should attempt to read this entire guide. It introduces you to all the features and procedures of the system and enables you to work with DKAdmin/DKBackup quickly.

If you are proficient in using DKAdmin/DKBackup, you may still have questions from time-to-time about a particular function or procedure. Use the Index to locate a subject or item that you may have questions about, or scan the Contents.

Conventions

Note Elaborates specific items or references other information.

Important! *Calls attention to important instructions or information.*

CAUTION! *Advises you that hardware, software applications, or data could be damaged if the instructions are not followed closely.*



Alerts you to precautions noted both on the equipment and in this guide.

WARNING! Alerts you when the given task could cause personal injury or death.

Letters in [brackets] represent buttons which have Directory Numbers on them. For example:

[PDN] Primary Directory Number button (the Extension Number for your telephone).

[SDN] Secondary appearance of a [PDN]. A [PDN] which appears on another telephone is considered an [SDN].

[PhDN] Phantom Directory Number button (an additional Directory Number).

[DN] any Directory Number button (also known as an Extension or Intercom Number).

Extra bold letters represent telephone buttons. For example: **999#**.

➤ denotes the step in a one-step procedure.

~ means “through”. For example: 5 ~ 10.

+ is used for multiple key entries.

Example: Press **Speed Dial + XX + Redial + Spkr (XX = 08~60 seconds)**.

Important Safety Instructions

WARNING! When using your telephone equipment, always follow basic safety precautions to reduce the risk of fire, electrical shock, and personal injury, including the following.

- Read and understand all instructions.
- Follow all warnings and instructions marked on the product.
- Unplug this product from the wall outlet before cleaning. Do not use liquid cleaners or aerosol cleaners. Use a dry cloth for cleaning.
- Do not use this product near water; for example, near a sink or in a wet area.
- Do not place this product on an unstable cart, stand, or table. The telephone may fall, causing serious damage to the unit.
- To protect the product from overheating, do not block or cover any slots or openings in the base Unit. This product should never be placed near or over a radiator or heat register. This product should not be placed in an enclosed cabinet unless proper ventilation is provided.
- Operate this product only from the type of power source indicated on the marking label.
- Do not allow anything to rest on the power cord. Do not locate this product where the cord will be damaged by persons walking on it.
- Do not overload wall outlets and extension cords, as this can result in the risk of fire or electrical shock.
- Never push objects of any kind into this product through the Base Unit slots, as they may touch dangerous voltage points or short out parts that could result in a risk of fire or electric shock. Never spill liquid of any kind on the product.
- To reduce the risk of electric shock, do not disassemble this product. Contact qualified service personnel when service or repair work is required. Opening or removing covers may expose you to dangerous voltages or other risks. Incorrect reassembly can cause electric shock when the appliance is subsequently used.
- Unplug this product from the wall outlet and refer servicing to qualified service personnel under the following conditions:
 - ◆ When the power supply cord is damaged or frayed.
 - ◆ If liquid has been spilled into the product.

- ◆ If the product has been exposed to rain or water.
- ◆ If the product does not operate normally when following the operating instructions. Adjust only those controls that are covered by the operating instructions. Improper adjustment of other controls may result in damage, and will often require extensive work by a qualified technician to restore the product to normal operation.
- ◆ If the product has been dropped, or the cabinet has been damaged.
- ◆ If the product exhibits a distinct change in performance.
- Do not use the telephone to report a gas leak in the vicinity of the leak.

WARNING! To reduce the risk of fire or injury to persons by the battery, follow these instructions:

- Use only battery pack model EXP9580 or EXP9586. Use of any other battery may cause a safety hazard.
- Do not dispose of the battery pack in a fire. The cell may explode. Under federal, state and local laws, it may be illegal to dispose of old batteries by placing them in the trash. Check with your local government for information on where to recycle or dispose of old batteries. If you cannot find the information you need, contact Toshiba for assistance.
- Do not open or mutilate the battery pack. Released electrolyte is corrosive and may cause damage to the eyes or skin, and, if swallowed, may be toxic. Cadmium is a chemical known to the State of California to cause cancer.
- Exercise care in handling the battery in order not to short the battery with conducting materials such as rings, bracelets, and keys. The battery or conductor may overheat and cause burns.
- Charge the battery pack provided with or identified for use with this product only in accordance with the instructions and limitations specified in the instruction manual provided for this product.
- Observe proper polarity orientation between the battery pack and battery charger.

Related Documents

The following documents can be used to reference more information about the Strata DK systems.

- *Strata DK Programming Manual* provides all instructions necessary to program the system and system record sheets, including ACD. It also contains the user guides in a reduced-size format.
- *Strata DK Installation & Maintenance Manual* provides installation instructions for configuring and installing the Strata DK14, DK40 and DK424. It also includes T1/DS-1 interface installation and configuration instructions, flowcharts to troubleshoot the systems, and user guides for stations and peripherals. An ACD Section provides instructions for installing ACD into the Strata DK424.

Your cordless digital telephone is designed and engineered to work with your Toshiba digital telephone system and provide you with reliability, long life, and outstanding performance. The cordless digital telephone is compatible with all Strata DK systems that support digital telephones (except Strata DK24/56/96 Release 3). All it requires for connection is a digital station port.

Your cordless digital telephone uses digital 900 MHz spread-spectrum technology, which represents state-of-the-art design and engineering. This provides unsurpassed range, several times greater than conventional analog or cordless digital telephones. It provides clarity that is so good, it is indistinguishable from corded telephones in most environments. It also provides fully secure communications for up to nine cordless digital telephones within a given environment.

Fully charged, your cordless digital telephone provides over 3 hours of talk time and 42 hours of standby. There is a fast charger in the handset and a trickle charger in the base.

The cordless digital telephone provides many of the same features as a 2000-series corded digital key telephone (DKT):

- ◆ 20-character Liquid Crystal Display LCD (displays top 16 characters of DKT)
- ◆ Four programmable buttons for feature or multiple-line access (same as first four buttons on DKT station port)
- ◆ Headset jack
- ◆ Handset volume adjustment (three levels)
- ◆ Two ring levels and a vibration mode
- ◆ **Cnf/Trn** button
- ◆ **Msg** button with Message Waiting LED
- ◆ **Hold** button

- ◆ Twenty-speed dial memory (stored in the telephone separate from 40 individual and system speed dial numbers)

Your cordless digital telephone offers two different modes of operation. You can use it either in conjunction with a 2000-series digital telephone, or on a stand-alone basis. When used with a DKT, both the cordless digital telephone and the DKT share the same digital station port on the PDKU. It also shares the same extension number.

You can switch between use of your DKT and your cordless, just by pressing a button. When used on a stand-alone basis, the cordless digital telephone attaches to its own digital station port on the PDKU.

Several useful accessories are available:

- ◆ Base wall mount
- ◆ Headset
- ◆ Heavy duty 5.5-hour battery
- ◆ Separate deep cycle charger

Applications

Your cordless digital telephone brings mobility and productivity to office telephones. Greater call access cuts down on “telephone tag” delays. Its compact design makes it easy to take with you.

Benefits

Your cordless digital telephone uses advanced technology and provides important features that place it far above the competition in functionality and value. You benefit from much greater performance than other cordless telephones currently available. This means better sound quality, longer range, greater security, multi-line access, helpful LCD display information, and many other important advantages.

The cordless digital telephone provides many advantages over a single-line analog or digital telephone. Some of those advantages are:

- ◆ Multi-line access is available on up to four programmable buttons. These buttons can be used for CO line appearances, multiple [DN] appearances, or features. If the cordless telephone is attached to a 2000-series desk telephone, the four programmable buttons are the same as the first four buttons on the desk DKT.
- ◆ Your cordless digital telephone rings to the same extension number as the regular DKT it is used with, enabling you to answer via either telephone. Both follow the same forwarding and hunting regardless of which telephone is in use. This is much simpler than having a separate extension number and standard station port for a single-line cordless, in which, if you use both phones, you must forward the DKT telephone to the single-line telephone (SLT).

An SLT cordless is not only a cumbersome alternative to the Toshiba digital cordless; but also, if you forget to forward your calls, you cannot receive the calls on your SLT cordless. With your cordless digital telephone it is easy. Just press a button, grab your cordless, and go!

- ◆ Message Waiting LED that is activated just like any regular DKT. This is a big advantage over a single-line cordless, which, for example, cannot light message waiting from voice mail.
- ◆ Spread-spectrum technology provides five to seven times greater range than conventional cordless telephones, making your cordless digital telephone much more useful and valuable.
- ◆ 900 MHz spread-spectrum operation provides maximum security with a frequency range that is almost impossible to scan. Regular 900 MHz cordless digital telephones are difficult to scan, but less so than spread spectrum. Analog cordless telephone frequencies are easy to scan and provide virtually no security from the outside. Hackers and thieves can use this to hear conversations and pick up credit card numbers.
- ◆ Sound quality is better on your cordless digital telephone than non-spread spectrum 900 MHz digital cordless phones. Sound quality on conventional analog cordless telephones is so poor by comparison that they are only practical for short range usage.

Cordless Digital Telephone Standard Parts

Your Toshiba cordless digital telephone includes the following items:

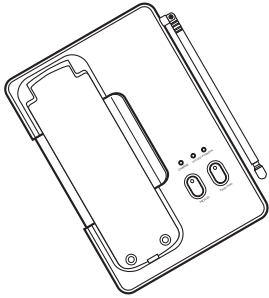

Base Unit

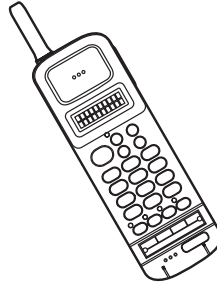

Handset

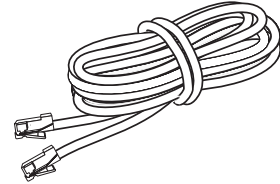

Telephone Cord (2 ft.)

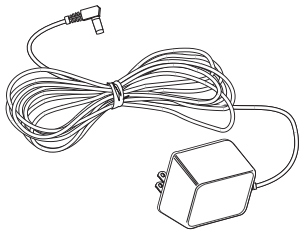

AC Adapter

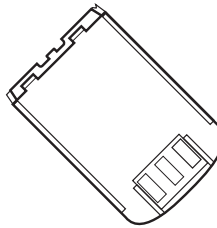

Rechargeable Battery

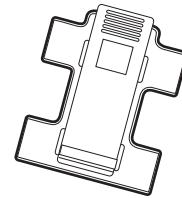

Belt Clip



User Guide

If any of these items are missing or damaged, contact your System Administrator.

Base Unit Controls and Functions

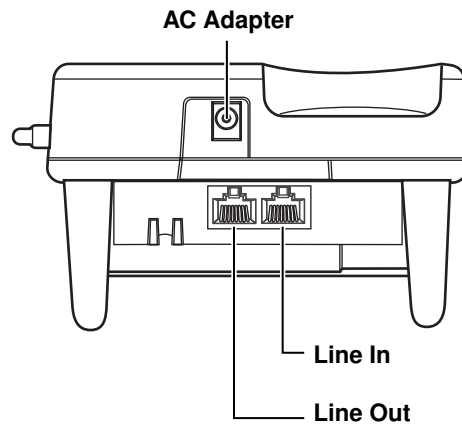
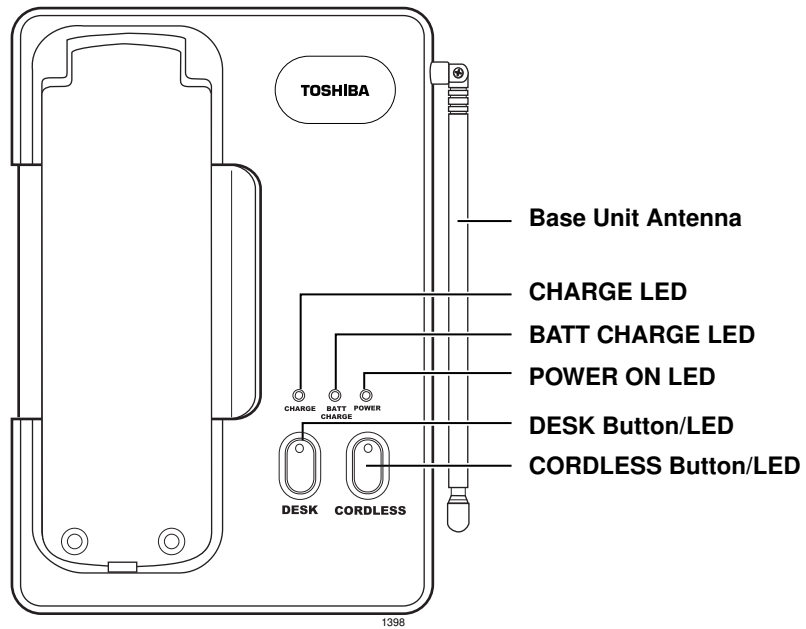

Features

Super Long Range 900 MHz Spread Spectrum

2-line, 10-digit LCD Display

Headset Jack

Ringer Volume Control

Handset Volume Control

Message Waiting LED

Single button access to Conference, Hold, Message Waiting, and Transfer features

Four Flexible Function Keys (First four keys of DKT port in Strata DK)

20-Number Memory Store and Search

Battery Charging System for Optional Standby Battery

2-Way Handset Mounting

Vibration Ringer Alert

Compact Handset Design

Important! *Your telephone system must be programmed for Auto Preference for your **TALK** button to work. If there is a shared digital telephone, you receive internal system dial tone automatically after picking up the handset of your deskset. For example, in a DK424 system, Program 32 must have a setting other than “00.” It is best to set Auto Line Preference to access Intercom dial tone.*

Step 1: Select Location

1. Select a location for your cordless digital telephone. Avoid excessive heat or humidity.
2. Place the cordless digital telephone’s base unit on a desk or tabletop near a standard 120V AC outlet and within reach of the digital telephone line connection to your Strata DK system.
3. Keep the base unit and handset away from sources of electrical noise (motors, fluorescent lighting, etc.).

Important! *Place the cordless telephone to the right of the DKT. If placed on the left of the DKT, the cordless antenna picks up a tone due to its close proximity to the DKT speaker and electronic parts.*

Step 2: Connect Telephone Cords

Your cordless digital telephone can be used as a stand-alone telephone or in conjunction with your deskset.

There are two telephone line jacks on the back of the base unit of your cordless digital telephone: “Line In” and “Line Out.” You can connect your cordless digital telephone to both the telephone line and a Strata DK digital telephone.

► **To use as a stand-alone telephone**

- Connect the modular jack labeled “Line In” to the telephone wall jack.

► **To use with a desk telephone**

1. Unplug the telephone line cord from your desk telephone.
2. Connect this cord to “Line In” of your cordless telephone.
3. Using the two foot modular cord that came with your cordless telephone, connect the jack labeled “Line Out” to the desk telephone.

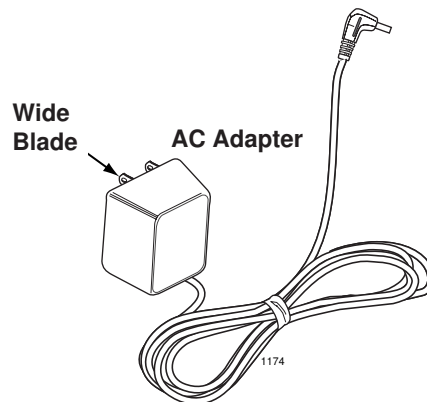

Step 3: Connect and Apply Power to Base Unit

Note The AC adapter furnished with this telephone may be equipped with a polarized line plug (a plug having one blade wider than the other). This plug fits into the power outlet only one way. If you are unable to insert the plug fully into the outlet, try reversing the plug. If the plug still does not fit, contact your facilities coordinator about replacing the obsolete plug. Do not alter the shape of the blades on the polarized plug.

1. Plug the AC adapter cord into the AC adapter input jack on the base unit.

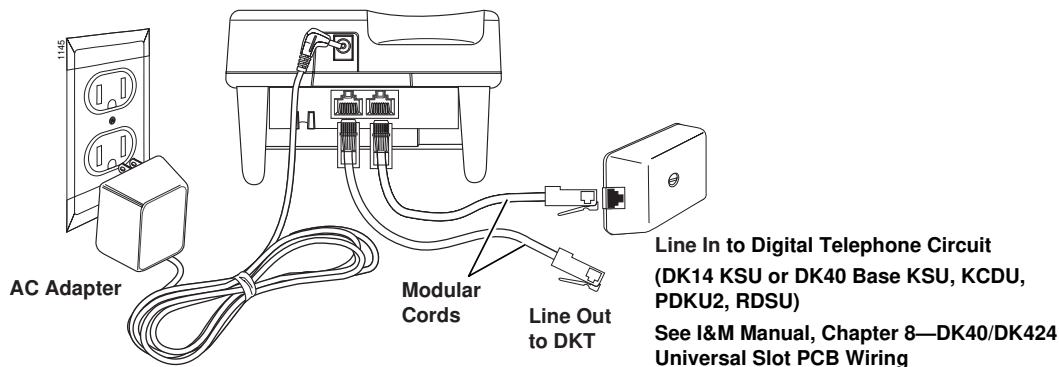

CAUTION! Use only the AC adapter supplied with your cordless digital telephone.

2. Plug the AC adapter into a standard 120 VAC wall outlet.
3. Route the power cord where it is not a trip hazard, and where it cannot become chafed and create a fire or electrical hazard.
4. Wrap the power cord around the notch on the bottom of the base unit as shown at the right.
5. Check to see that the power LED is on, indicating the telephone has power.

6. Before using your cordless digital telephone, be sure to raise the antenna to the vertical position.

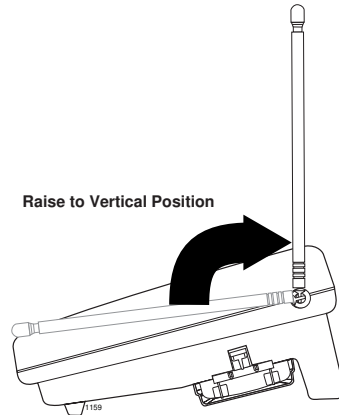
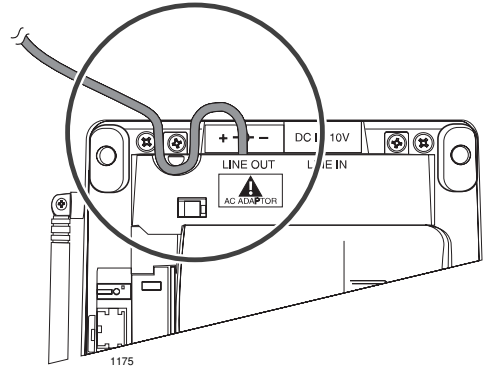

Step 4: Attach Belt Clip to Handset (optional)

► To attach the belt clip to the handset

1. Snap the tabs of the belt clip into the notches on the sides of the handset.
2. Use the belt clip to attach the handset to your belt or pocket for convenient portability.

► To remove the belt clip

1. Pry one tab at a time from the notch on the side of the handset.
2. Carefully lift the belt clip off.

Note The belt clip is designed to fit snugly onto the handset.

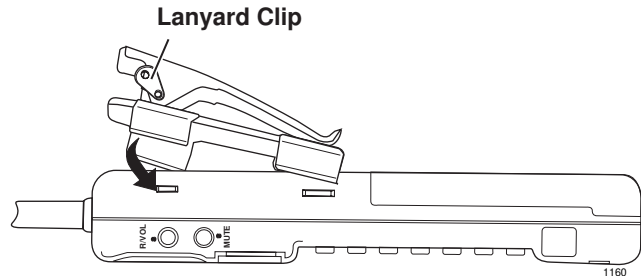

Step 5: Install Handset Battery Pack

1. Place a charged battery pack onto the handset so that it slides easily along the ridges.

If your battery is not charged, see [“Removing and Charging Your Battery Pack”](#) on Page 21.

2. Slide the battery pack up onto the handset until it clicks into place.

You are now ready to configure your cordless digital telephone. See [“Configuration”](#) on Page 25.

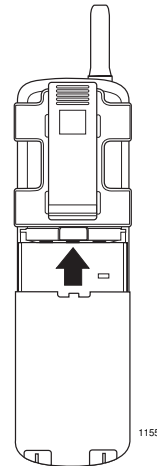

Removing and Charging Your Battery Pack

Important! *Before using your new cordless digital telephone, the battery must be charged continuously for six to eight hours.*

► **To remove the handset's battery pack**

1. Press in on the battery pack release latch.
2. Slide the battery pack off the handset.

Note You may have to pull hard to slide the battery pack off, when the handset is new.

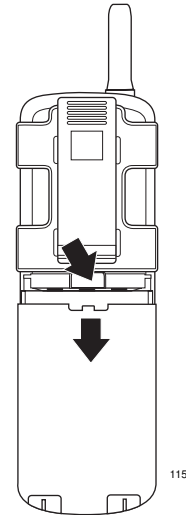

► **To charge the handset's battery pack**

1. Place the handset on the base unit.
2. Make sure the CHARGE LED lights. If it does not light, check to see that the AC adapter is plugged in and that the handset is making good contact with the base unit.

Charging Extra Battery Packs

The base unit of your cordless digital telephone is equipped with a battery charger for charging an extra battery pack. This compartment has a latch that keeps the battery pack in place during charging.

► To charge extra battery packs

1. Position the battery pack so the inner side is facing toward the top of the base unit.
2. Slide the battery pack into the charging compartment until it clicks into place.
3. Make sure the BATTERY CHARGE LED lights. If it does not light, check to see that the AC adapter is plugged in, and that the battery pack is seated into the charging compartment.

Note Charge the standard 400 mAh battery pack without interruption for six to eight hours. Charge the optional 730 mAh extended battery pack without interruption for eight to ten hours.

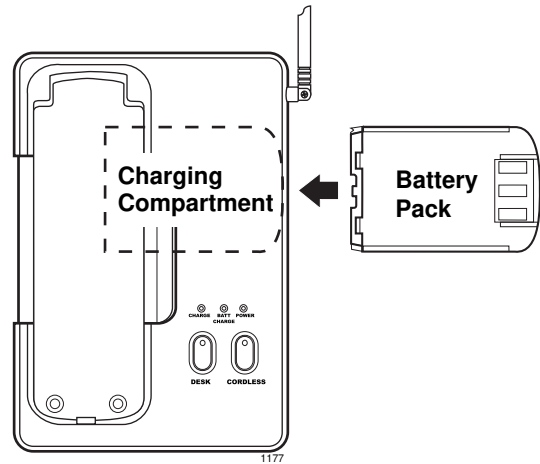

Tips on Extending Battery Pack Life

Battery Memory Effect

All rechargeable nickel cadmium batteries can develop a “memory” (reduced charge capacity) caused by repeated charge and discharge cycles. Batteries that have developed this effect do not operate to their fullest capacity.

► To avoid memory effect

- Operate the unit until the battery pack is completely discharged before recharging. For example, use the handset off the base all day. Only replace the handset on the base at night after a full day of use. Do not “top off” the charge after using the battery for a short time.

► To erase memory effect

- Operate the unit until the battery pack is completely discharged, then recharge it fully. Repeat this process at least three times.

LCD Low Battery Indicator

When the battery pack in the handset is low and needs to be charged you see this message on the display and the handset beeps.

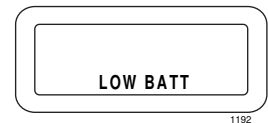

1192

Low Battery Symptoms

On a Call	In Standby Mode
Only the TALK key operates.	None of the keys operate.
Handset beeps once every three seconds.	Handset beeps once.
Complete your call as quickly as possible.	Cannot make call.
Replace battery pack.	Replace battery pack before making a call.

To restore your battery capacity, return the handset to the base unit for charging or replace the handset battery pack with another charged one.

You can configure three items in your cordless digital telephone that affect the way it works with the Strata DK business telephone system. These are:

SOFT KEY	<p>F1 (On) causes the deskset to turn on the soft keys whenever the mode is changed from cordless to DKT.</p> <p>F1 (Off) causes the deskset to turn off the soft keys whenever the mode is changed from cordless to DKT.</p>
SOFT KEY LOCK (MODE 70/71)	<p>F2 (On) allows the Soft Key Mode 70/71 (Soft key Off/On) function to pass from the deskset to the Strata DK for controlling the soft key mode.</p> <p>Do not use this F2 (On) setting unless you have Release 3 of Strata DK280. Use with older systems may cause a system malfunction. Use F2 (Off).</p> <p>F2 (Off) locks the Soft Key (Mode 70/71) function from passing from the deskset to the Strata DK.</p>
RCV LEVEL	<p>F2 (On) sets the receive level to normal level.</p> <p>F2 (Off) sets the receive level to 4-dB level (lower volume).</p>

The above three settings default to the ON state.

Your cordless digital telephone can operate in either the DKT or the cordless mode and can be programmed whenever the telephone is idle. When entering the program mode during cordless operation, all calls coming to this station are ringback tone until the program mode is ended. Entering the program mode during DKT operation has no effect on current call status.

Entering Program Mode

► To enter the program mode

1. Remove the handset from the base unit.
2. Press and hold * and # at the same time.

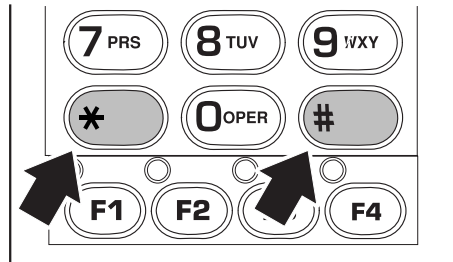

1178

3. While holding * and #, press **TALK**.

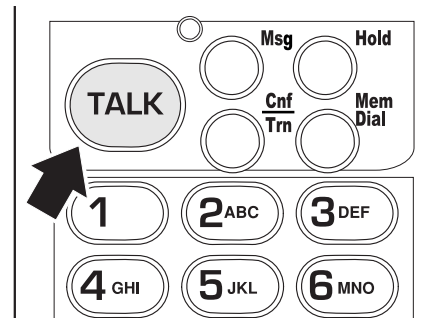

1178b

4. Release all three keys.

5. Press the **R/VOL** button on the upper right side of the cordless handset until you toggle to the DATA STORE settings screen.
6. Press **0** to toggle the settings for each program step or store (save) the setting when in DATA STORE step.
7. Press **TALK** at any time to exit PROGRAM without saving changes. To save the changes step to DATA STORE and press **0** before pressing **TALK**.
8. Press **MUTE** to step through the program steps in the reverse order.

The LEDs above the **F1~F3** buttons indicate the current setting for each of the program steps. Each time the feature is entered and digit **0** is pressed these LEDs change their indication.

You see the following screens on the cordless LCD prompting you to configure your handset:

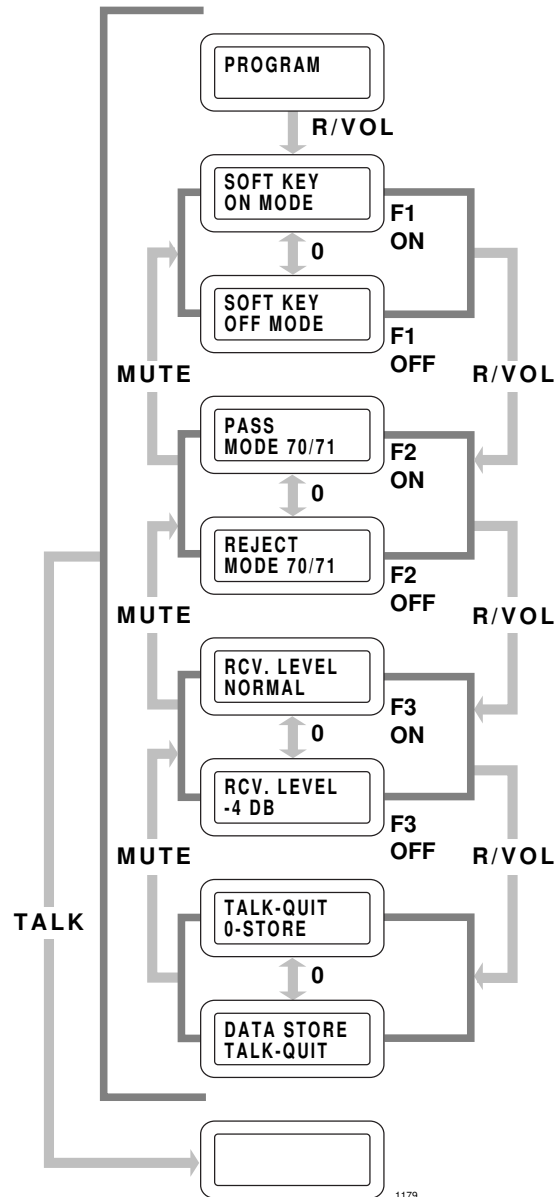

Handset Controls

Handset Volume Level

- Press the **R/VOL** button on the side of the handset while on a call to select a loud or soft volume level.

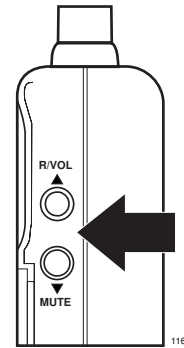

Ringer Volume Level

- While the telephone is idle, press the **R/VOL** button on the side of the handset to select ring volume. When the handset is returned to the base, the ring volume automatically switches to RING HIGH.

Note When the display is set for RING OFF, you receive a vibration alert instead of the audible ring tone.

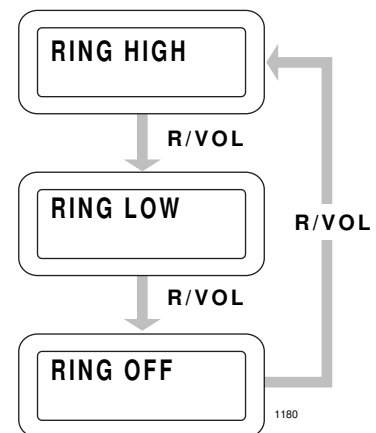

Mute

- Press and hold the **MUTE** button to consult another person in the room without the caller hearing you. Release the **MUTE** button to continue the conversation.

Using the Handset

- Pick up the handset and press **TALK**.

You may see:

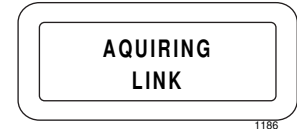

When the cordless digital telephone communicates between the base unit and the handset, the screen goes to standby, and the telephone is ready to use.

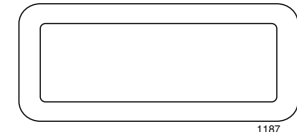

When talking and the handset is at the range limit of your cordless digital telephone, you may see:



Take the following action:

- During a call, move back in range within 20 seconds.
- In standby mode, move back within range.

When the display indicates **DKT MODE**, the telephone was not transferred to cordless mode at the base.

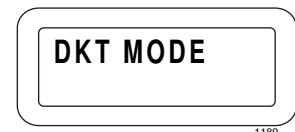

Charging the Handset

For more information see [Page 21](#).

► To charge your handset

- Place the handset on the base unit either face down or face up, with or without the belt clip attached. (The battery pack in the handset automatically recharges in either position.)

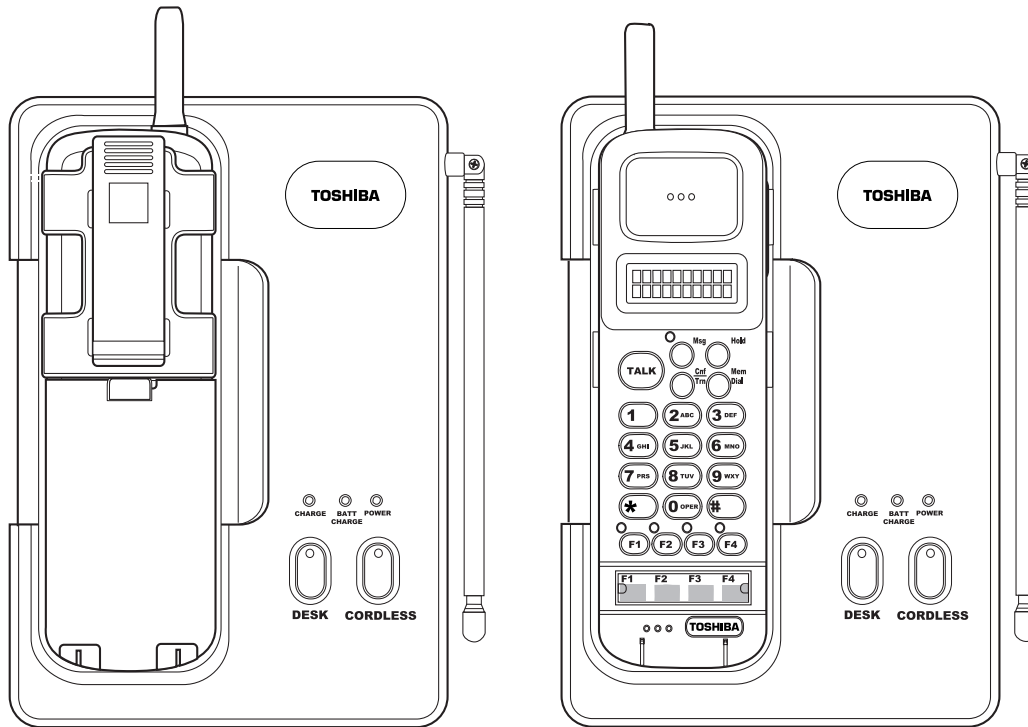

Switching a Call to Your Cordless Digital Telephone

You can switch a call from the deskset to the cordless digital telephone or vice versa whether idle or talking.

Note Transferring while idle or when calls are on hold results in a steady light (skipping the flashing state).

► To transfer an active call

1. Press **CORDLESS** on the base unit.

The CORDLESS LED flashes.

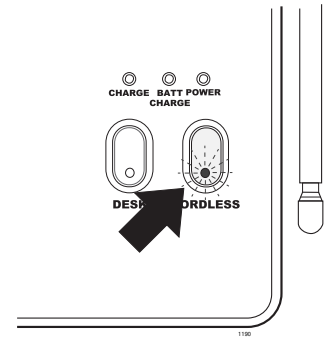

2. Pick up the handset and press **TALK**.

The CORDLESS LED lights steady. The DKT LEDs go out and LCD display shows CORDLESS MODE.

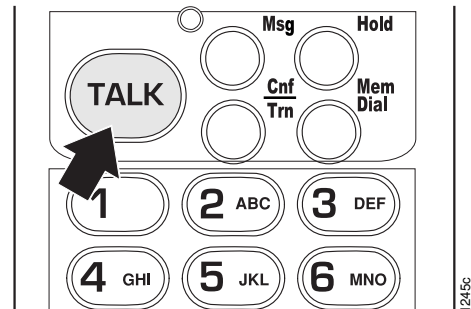

3. When you finish the call, place the handset back on the base unit to automatically hang up.

If the telephones are idle, the transfer takes place immediately without the need to pick up the handset.

Switching a Call to the Desk Telephone

1. Press **DESK** on the base unit.

The DESK LED flashes.

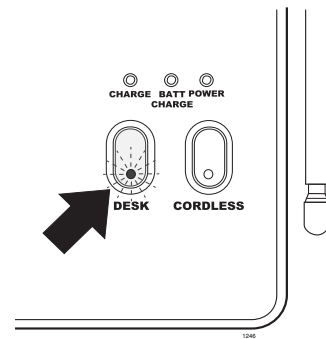

2. Pick up the handset on your desk telephone.
3. Hang up your cordless digital telephone handset.

The DESK LED lights steady.

Note If the cordless AC Adapter is unplugged or if the Strata DK system is turned off, the mode automatically changes to the CORDLESS mode.

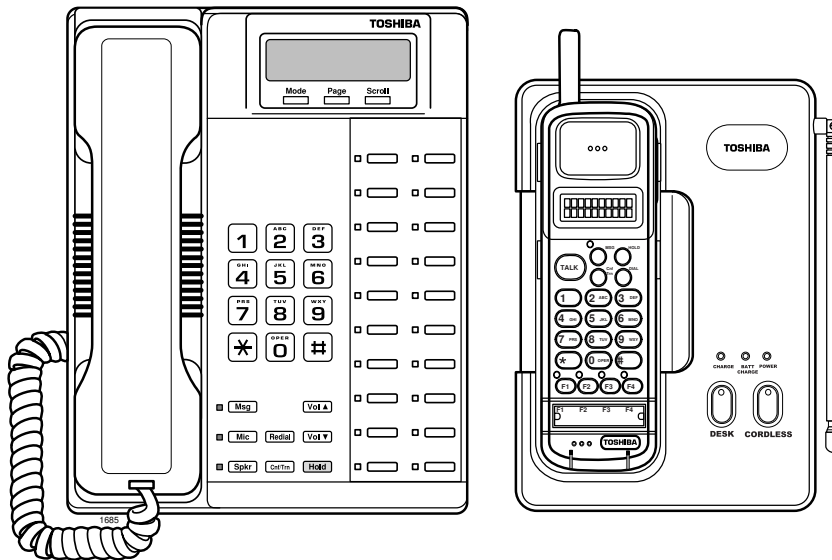

Cordless Digital Telephone with Digital Telephone

Using Memory

► To store a number

1. Remove the handset from the base unit.
2. Press **Mem Dial**.
3. Enter the number (up to 16 digits) you want to store.
4. Press **Mem Dial**.
5. Enter the number (01~20) for the memory location you want to use.

You hear a beep and see:

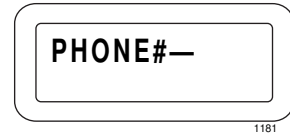

You see:

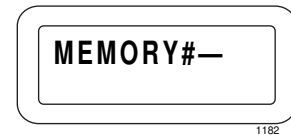

You hear a confirmation beep and see the message. The telephone then returns to standby.

Note After pressing **Mem Dial** the second time, you have 20 seconds to enter the memory location number you wish to use. Otherwise, an error tone sounds and the unit returns to standby.

► To erase a stored number

1. Remove the handset from the base unit.

You see:



2. Press **Mem Dial** twice.

You see:



3. Press the memory location number you want to clear.

You hear a long beep and see a screen confirming that you have erased that number from memory.



► To dial a stored number

1. Remove the handset from the base unit.

2. Press **TALK**

...or press a designated function key with a line assigned to it. For example: Press **F2**.

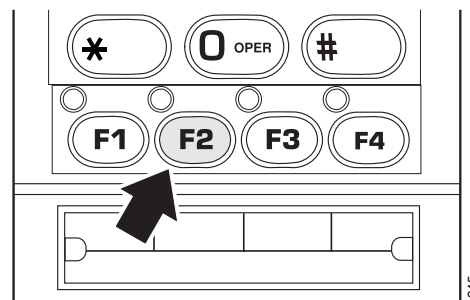

3. Press **Mem Dial**.

4. Enter the two-digit memory number (01~20) for that number from the keypad.

Your cordless digital telephone then dials the previously stored number. If you select a memory location that does not have a stored number, the handset beeps rapidly and the telephone does not dial.

Chain Dialing

On certain occasions, after dialing a number, you may be requested by the party or service you are calling to enter a special access code, such as when performing a banking transaction. The access code can be stored in one of the 20 memory locations.

1. Remove the handset from the base unit.
2. Make the call by dialing directly or from one of the stored numbers in memory.
3. When prompted by the called party, press **Mem Dial** (as shown) and the memory number of the access code at the appropriate time.

Example:

1. Dial the number for your bank.
2. When the bank requests your account number press **Mem Dial**.
3. Using the handset, enter the two-digit memory location (01~20) for your account number. Your handset dials the number and you may proceed with your transaction.

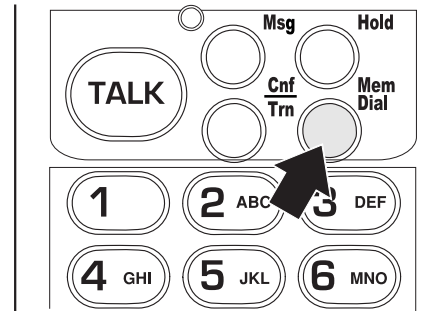

This chapter gives you all of the cordless digital telephone features in alphabetical order beginning on [Page 47](#). Your cordless digital telephone provides many of the same features as a 2000-series corded digital telephone. In addition to the **Msg, Hold, Conf/Trn** and **Mem Dial** functions, you can use your cordless digital telephone's **F1~F4** buttons to invoke the features listed below or to gain multiple-line access.

When sharing the same station, your cordless **F1~F4** buttons perform the same functions as the first four buttons on a 2000-series telephone. The **F1~F4** buttons were preassigned upon system installation. Ask your System Administrator which **F1~F4** button functions you may or may not have.

If you are not using the programmable **F1~F4** buttons, you can use the alternate steps in this chapter to invoke the features listed below.

- ◆ **Pooled Line Grp**
- ◆ **Release and Ans**
- ◆ **Park in Orbit**
- ◆ **Park and Page**
- ◆ **Redial**
- ◆ **Call Frwd All Calls**
- ◆ **Call Frwd Busy**
- ◆ **Call Frwd No Answer**
- ◆ **Speed Dial**
- ◆ **Call Frwd Busy/NANs**
- ◆ **Call Frwd External**
- ◆ **Auto Callback**
- ◆ **Account Code**
- ◆ **Auto Busy Redial**
- ◆ **Directed Pickup**
- ◆ **Group Pickup**
- ◆ **Do Not Disturb**
- ◆ **LCD Msg Select**
- ◆ **Privacy on Line**
- ◆ **Privacy Release**
- ◆ **DSS**
- ◆ **Tone Dial Select**
- ◆ **Start**
- ◆ **Subaddress**

There may be some feature operation differences on older version systems - compared to Strata DK424 (e.g., Strata DK280, Strata DK24/56/96 and Strata DK14 & DK40). Please see

“Access Codes” on Page 92 for Feature Access Code sequences that match your Toshiba telephone system. Also see the Digital Telephone User Guide for more information.

Before You Begin

If you are a new user of the cordless digital telephone, find out if your Strata DK system has Tone or Voice First Signaling. The difference is Tone Signaling rings while Voice First Signaling notifies you with a long tone, and then the caller’s voice. Both signals are enabled in system programming and determine how you make and answer calls on your cordless digital telephone.

You can toggle between Tone and Voice First Signaling on a call-by-call basis.

► To change the signaling method

1. Press a [DN] button and dial another station [DN].
2. Press **1**.
3. Speak to your party when they answer.

If Tone First Signaling is enabled, you hear a ring tone (one second) every four seconds.

If Voice First Signaling is enabled, you hear a tone burst and then you can talk over the called station speaker.

After you press **1**, the other method is activated.

► To answer a call when you have Voice First signaling

- Talk in the direction of your telephone
...or answer the call normally.

► To answer a call when you have Tone First signaling

If you hear successive ring tones, you have *Tone* First Signaling.

- Lift the handset.

Note You can change to the alternate signaling method when making a call on a call-by-call basis by pressing **1** after dialing an internal telephone number.

Quick Reference

The following topics are quick references for using your telephone's standard features.

Making an Outside Call

You can make calls to or receive calls from telephones outside of the Strata DK system by dialing direct or and using CO Line Access Codes.

► To direct dial an outside number

1. Press **TALK**
...or press any available **Line** button.
2. Dial a telephone number.

The [DN], Line, or Pooled Line Grp LED lights.

Line buttons can be labeled **CO Line** (outside CO Line), **Line**, or **Pooled Line Grp**. After selecting a Line, you should hear dial tone and the LED lights steady.

Dial tone stops after you dial the first digit.

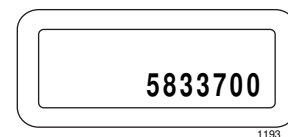

1193

► To use CO Line Access Codes to dial an outside number

1. Press **TALK**.
2. Dial a CO Line access code.
See [“Access Codes” on Page 92](#).
3. Dial a telephone number.

You hear internal dial tone and the LED lights steady (with INT/PDN automatic off-hook selection programmed).

You hear CO Line dial tone and the LED continues to flash at the in-use rate.

Dial tone stops after you dial the first digit.

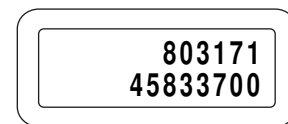

1194

Making an Outside Call to an ISDN Trunk

1. Access an outside CO line
2. Dial the number.
3. Press **Start**.

The dialed digits will not be sent until you press this button or until the timer expires. See [“ISDN Outgoing Calling” on Page 64](#) for more information on ISDN calls.

Making an Internal Call

You can make calls to and receive calls from other stations in the Strata DK system.

► To dial an internal call

1. Press **TALK** or a [DN].
2. Dial a [DN].

You hear dial tone and the LED lights steady.

Notes

- If the system is set for Voice First Signaling, make a voice announcement when you hear a single tone.
- If the system is set for Tone Signaling, you hear repeated ring tones and you should wait for the call to be answered.
- If the called station does not answer, you can leave a message waiting by pressing **Msg** or **7**.

► To recall a busy station

- Press **4** to set Automatic Call Back (ACB).

► To override a busy station

- Press **2**
- ...or **3**.

Busy Override is activated (use only if the called station is not equipped for OCA).

Executive Override (system programmable option) is activated.

Answering Calls

► To answer a call on a CO Line or [DN]

- Press the flashing [DN], **Line**, or **TALK** button.

The LED changes from the flashing incoming call rate to steady.

► To answer a call on Pooled Line Grp

1. Press the flashing **Pooled Line Grp** or **TALK** button.

The LED changes from the flashing incoming call rate to steady. If another call comes in during the first call, place the call on hold or transfer it, then answer the second call.

Note A warning tone is given when you are on a **Pooled Line Grp** call which indicates an incoming call.

2. Press **Release and Ans** ...or **TALK**

► To answer a transferred call

- Press **TALK** ...or the flashing [DN] key.

You hear an internal ringing tone. The cordless digital telephone continues to ring whether the deskset is set for Voice First or Tone Signaling.

The [DN] or Line LED is steady when you are connected to the call.

Transferring Calls

You can transfer calls to a idle or busy station, but you cannot transfer calls to a station that is in the DND mode.

► To transfer a call (using Camp-on)

1. Press **Cnf/Trn**.
2. Dial the [DN] where the call is to be transferred.

The Line or [DN] LED flashes at the conference rate. You hear internal dial tone.

The [DN] could be the [DN] of a telephone, a Hunt Group Number, or ACD Group [DN], etc.

3. Announce the call.

After dialing, you hear a single tone.

Note If the call was made with Tone Signaling instead of Voice First Signaling, you hear ringing tone.

If the called station does not answer, you receive a recall ring (when your station or [DN] is idle). The ring is set by system programming.

4. Hang up

The Line LED changes to steady when the called station connects with the transferred call.

...or press **Line**, [DN] + **42** to reconnect to the transferred line before the call is answered or busy tone is received.

The Line LED changes to steady red when the called station connects with the transferred call. After you hang up, the Line LED begins to flash at the on-hold rate or if you transferred the call from a [DN], the [DN] LED goes out. The CO Line or [DN] camps onto the called station and the called station receives a warning tone.

You receive a recall ring when your station or [DN] is idle and camp-on is cancelled when the called station user fails to answer within a predetermined time. Repeat the procedure if necessary.

Conferencing Calls

► To conference calls with stations only

As many as four stations can be conferenced on one [DN].

1. Press **Cnf/Trn**.

You hear internal dial tone and the LED flashes at the conference rate.

2. Dial a [DN].

The [DN] could be for a telephone or department.

3. Press **Cnf/Trn** after the party answers.

All parties are conferenced and the [DN] LED from which the conference originated lights steady.

► To add a second Line

<ol style="list-style-type: none"> 1. Press Cnf/Trn. 2. Dial the next telephone number. 3. Press Cnf/Trn after the party answers. 	<p>You hear dial tone. The [DN] or Line LED flashes at the conference rate if the call is on a [DN] or Line button.</p> <p>All parties are conferenced. You can add one more station to a two-line conference.</p> <p>Note If you receive a busy tone or the second station does not answer, return to the original connection by pressing the original [DN] or Line or hanging up.</p> <p>If both lines appear on your telephone, both Line LEDs lights steady (if you used Line buttons). If you established the two-line call on a single [DN], it lights steady.</p>
--	---

► To add a station to a line call

<ol style="list-style-type: none"> 1. Press Cnf/Trn. 2. Dial the [DN] of the station to be added. 3. Press Cnf/Trn after the party answers. 	<p>You hear dial tone. The [DN] or Line LED flashes at the conference rate.</p> <p>If you receive a busy tone or no answer, press Cnf/Trn to return to the original connection.</p> <p>All parties are conferenced. The [DN] or Line LED lights steady.</p> <p>Up to three stations (including your own) can conference with one line.</p> <p>The new station is not conferenced until you answer by lifting the handset or pressing a [DN].</p>
--	---

Placing/Retrieving Calls on Hold

Calls on hold may be released automatically if the held party hangs up and the network provides a hold-release signal. See [Page 45](#) for the Automatic Hold feature.

► To hold a call that appears on a Line or [DN] button

- Press **Hold**.

The Line or [DN] LED flashes green at the on-hold rate.

You hear recall tone when your station is idle (or two times only when busy) if you do not retrieve the held call before “Hold the recall” time set in system programming expires.

► To place a Handsfree Answerback call on hold

1. Press **TALK** or the flashing [DN] to answer the call.
2. Press **Hold**.

You are connected to the incoming call.

The Line or [DN] LED flashes green at the on-hold rate.

You hear recall tone when your station is idle (or two times only when busy) if you do not retrieve the held call before “Hold the recall” time set in system programming expires.

► To retrieve the held call

- Press **Line** or the [DN] which is on hold.

The Line or [DN] LED flashes at the on-hold rate.



1195

► **To place a call on Exclusive Hold**

Exclusive Hold enables you to place a call on hold so that only you or somebody using a Call Pickup code at another station can retrieve it.

- Press **Hold** twice.

The Line LED flashes at the exclusive hold rate.

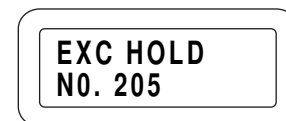

1196

► **To retrieve a call on Exclusive Hold**

- Press the **Line** button that is on Exclusive Hold.

Another station user can pick up the call by dialing **#5** plus your station number, or by dialing **#5#7** plus the CO Line number (**001~200**) that the call is held on.

Using Automatic Hold

Automatic Hold enables you to process calls more quickly, because you can automatically place a call on hold by pressing another **Line** or a [DN] button. You do not have to press the **Hold** button. You can also switch between a new call and the original call without having to press **Hold**. Automatic Hold is assigned on a station-by-station basis in system programming.

► **To use Automatic Hold**

- Press another **Line** or [DN] to receive or originate a new call, while on one call.

The original Line or [DN] LED flashes at the on-hold rate and the original call is placed on hold.

The LED of the new call lights steady and the new line is accessed.

► **To switch between calls**

- Press **Line** or [DN] of the held call.

The Line or [DN] LED just placed on hold flashes at the on-hold rate, and the LED of the Line just accessed lights steady.

Calling the Attendant Console

There are three ways to call the Attendant Console depending upon system programming. You can call any Attendant Console, a particular Attendant Console, or all Attendant Consoles.

➤ To call any console

- Press a [DN] + **0**.

The call rings the Attendant Console. Dial 0 calls rotate between the consoles if more than one console is installed.

➤ To call a specific console

- Press a [DN] + the console's [DN] ____.

The call rings the console's Incoming [DN] (**In-DN**) button.

Note Your System Administrator can provide the Attendant Console Incoming [DNs].

➤ To make an emergency call to all consoles

- Press [DN] + the emergency access code **#400**.

The call rings all consoles (**Emgr** button).

Tone/Pulse Dialing

With some older Central Offices, you may have to make calls using rotary dial pulses on outside lines. To access remote equipment (such as an answering machine) requiring Dual-tone Multi-frequency (DTMF) tones while on these lines, you must set your telephone for tone dialing after you have dialed the telephone number. Your telephone must have a **Tone Dial Select** button assigned in system programming to access this feature.

➤ To change to Tone Dialing

1. Dial a telephone number on a line programmed for rotary dial pulses.
2. Press **Tone Dial Select** while the call is in progress.

Although the line is programmed for rotary dial pulses, you can access the line and dial the telephone number like any other call described in this guide.

The Tone Dial Select LED lights steady, and you can send DTMF tones with your dial pad. If the LED is off, tone dialing is not selected, and you cannot send DTMF tones.

Note When originating or receiving a new call, the system automatically places the line in the dial pulse mode.

Account Code Calls

Account Codes can be entered before or after a call. Some of the code applications include billing, tracking, and line restriction. Account Codes are recorded by the system and can, along with the details of the calls they are associated with, be printed out on a Station Message Detail Recording (SMDR) report.

Forced Account Codes

Some applications may require that you enter a Forced Account Code before dialing the telephone number.

► To use a Forced Account Code

- | | |
|-----------------------------------|---|
| 1. Access a line. | You hear dial tone after accessing a line. If you dialed with LCR, you do not hear dial tone. See “Access Codes” on Page 92 . |
| 2. Enter the Forced Account Code. | Dial tone stops after you dial the first digit. You hear dial tone after you press the last digit of a valid account code, or busy tone if you dial an invalid code. If you dial with LCR, you do not hear dial tone. |
| 3. Dial a telephone number. | Any digits that you dial after entering the code is entered in Step 2 are treated as part of a telephone number. |

Emergency Override of Forced Account Codes

You can bypass Forced Account Codes with three emergency numbers including 911. See your System Administrator for these numbers.

Voluntary Account Codes

Voluntary Account Codes are optional and can be entered after accessing a CO Line or during a call that you originated or received. The outside party cannot hear the tones you are entering.

Voluntary Account Codes can be set in system programming to change the Toll Restriction classification of your station. See your System Administrator for more information. If your station is programmed not to verify Account Codes, you do not hear a confirmation tone.

► To use a Voluntary Account Code

1. Press **Account Code**

...or **Speed Dial + 50**

...or *** + 50**.

2. Enter the Account Code.
3. Repeat Steps 1 and 2 to enter another account code (the last code entered is recorded).

Your conversation is not interrupted. Some telephones require that you enter the account code before dialing a telephone number. If a valid account code is not entered, dialing external calls may be restricted.

You hear confirmation tone (one-half second duration) if the code is valid. If the code is invalid, you hear two short tones.

Notes

- Any digits dialed after the code has been entered are treated as part of the outside telephone number.
- Voluntary Account Codes must be entered before the call is disconnected.

Verified Account Codes

If the system is set for Verified Account Codes, you must enter specific codes when entering Forced or Voluntary Account Codes. Verified Account Codes are established in system programming or by designated stations.

Alarm Reset

Your Strata DK system can be connected to a facility alarm system. All telephones produce a startling tone whenever this alarm is activated. Stations with an **Alarm Reset** button can reset the alarm by pressing the **Alarm Reset** button.